

D171 / D171EXS PN25



D171 Bronze Ball Valve

D171EXS Extended Stem Bronze Ball Valve

Crane D171 Ball Valves are light, compact units which are easy to install and operate, yet their robust construction ensures long, trouble free service life.

In addition the D171 and D171EXS are WRAS approved.

Materials

PART	MATERIAL	SIZES
Body	Bronze BS EN 1982 CC491K	All
Seat Retainer	Bronze BS EN 1982 CC491K	All
Ball	DZR Brass BS EN 12165 CW602N	All
Seat Ring	PTFE	All
Stem	DZR Brass BS EN 12164 CW602N	All
Packing	PTFE	All
Gland Nut	DZR Brass BS EN 12164 CW602N	1/4 - 2
Lever	Mild Steel (Zinc Plated)	All
Screw	Mild Steel (Zinc Plated)	All
Lever Cover	PVC	All
Extension Housing	Aluminium	D171EXS
Extension Stem	Brass BS EN 12164 CW602N	D171EXS



D171



D171EXS

Dimensions & Weights

SIZE (inch)	WEIGHT (kg)	A (mm)	B (mm)	C (mm)	C1 (mm) D171EXS	D (mm)
1/4	0.15	46	10	39	-	81
3/8	0.15	46	10	39	-	81
1/2	0.22	57	15	52	97	92
3/4	0.45	67	20	58	98	92
1	0.69	77	25	66	118	127
1 1/4	1.12	91	32	72	124	127
1 1/2	1.67	103	40	82	142	142
2	2.93	122	50	90	149	142
2 1/2	4.98	153	65	117	-	202
3	8.75	179	80	132	-	282

Dimensional Drawing

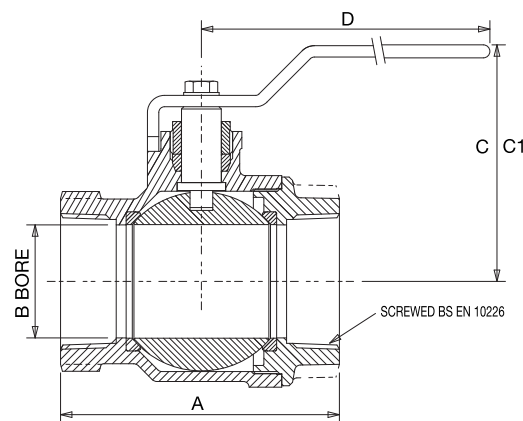

Pressure/Temperature Ratings

TEMPERATURE (°C)	-10 to 100	110	120	186
PRESSURE (BAR)	25.0	23.4	21.8	10.5

Intermediate pressure ratings shall be determined by interpolation.

PRESSURE RATING: PN25

TEMPERATURE OPERATING RANGE: -10 to 186°C

UK END CONNECTION: Taper threaded to BS EN 10226-2 (ISO 7-1) formerly BS 21

US END CONNECTION: ANSI B1.20.1 (please add suffix AT to denote American Thread)

OPERATOR: Lever

SPECIFICATION: Quarter Turn, Tight Shut-off.

This valve is not suitable for use on group 1 gases or unstable fluids, as defined by the Pressure Equipment Directive 97/23/EC.